

SPECIFICATIONS FOR LCD MODULE

MODEL NO.
BG320240F-BNHNHN\$
VER.01



FOR MESSRS:

ON DATE OF:

APPROVED BY:

BOLYMIN, INC.

5F, No. 38, Keya Rd., Daya Dist., Central Taiwan Science Park, Taichung City, 42881, Taiwan.

Web Site:<http://www.bolymin.com.tw> TEL:+886-4-25658689 FAX:+886-4-25658698

CONTENTS

1. Numbering System
2. Handling Precaution
3. General Specification
4. Absolute Maximum Rating
5. Electrical Characteristics
6. Optical Characteristics
7. Interface Pin Function
8. Power supply for LCD Module and LCD operating voltage adjustment
9. Backlight information
10. Quality Assurance
11. Reliability
12. Appendix
 - 12-1 Drawing
 - 12-2 Block Diagram
 - 12-3 Timing characteristics
 - 12.4 RAIO 8835A controller

1. Numbering System

B	G	320240	F	-	B	N	H	N	H	N	\$	-
0	1	2	3		4	5	6	7	8	9	10	11

0	Bolymin	B										
1	Module Type	C	Character type	P	TAB /TCP type							
		F	COF type	R	Color STN							
		G	Graphic type	L	OLED							
		O	COG type	Z	Customize							
2	Format	2004	20 character type,4lines									
		12232	122 × 32 dots									
3	Version No.	F										
		-										
4	LCD Color	B	STN / Blue, OLED/Blue	H	HTN							
		C	Color	T	TN							
		F	FSTN	Y	STN/Yellow-green							
		G	STN/Grey	D	OLED/Blue+Yellow							
		A	OLED/Blue+Yellow+Green	E	OLED/Yellow							
		L	OLED/Green	R	OLED/RED							
		W	OLED/White	J	ASTN							
		K	DFSTN	V	VA LCD							
5	LCD Type	R	Positive/reflective	M	Positive/ transmissive							
		P	Positive/transflective	N	Negative/ transmissive							
		T	Negative/ transflective									
6	Backlight type/color	L	(LED)Array/yellow-green	G	(LED)Edge/yellow-green							
		M	(LED)Array/amber	H	(LED)Edge/white							
		R	(LED)Array/red	D	(LED)Edge/blue							
		U	(LED)Array/blue	E	(EL)white							
		W	(LED)Array/white	B	(EL)blue							
		C	(CCFL) white	F	(LED)Array/RGB							
		Y	(LED)Array/yellow	N	No backlight							
		O	(LED)Array/orange	K	(LED)Edge/green							
		A	(LED)Edge/amber	Q	(LED)Edge/red							
		J	(LED)Array/green	I	(LED)Edge/RGB							
		Z	(LED) arrayred/green	P	(LED)Edge/orange							

		S	(LED)edge/RGW	T	(LED)edge red/green
		V	EL blue/green	X	(LED) Edgewhite /red
7	CGRAM Font	J	English/Japanese Font	C	English/Cyrillic Font
		G	Chinese(simple)	H	English/Hebrew Font
		E	English/European Font (ST7066U0B-BB)	S	English/European Font (ST7066U-0E-BB)
		F	Chinese(traditional)	M	Japanese-Kanji
		Z	Z=Chinese(simple)+Chinese (traditional)+Japanese+Korean	K	Korean (only for BG16032A BG24064C)
		A	English/Arabic Font	D	Chinese (simple/traditional) English/Japanese
		B	English/Japanese/European	N	None
8	View Angle /Operation Temperature	B	Bottom/Normal Temperature06:00	W	Top/Wide Temperature 12:00
		H	Bottom/Wide Temperature 06:00	E	Top/Ultra Temperature 12:00
		C	9H/Normal Temperature 09:00	U	Bottom/Ultra wide Temperature 06:00
		T	Top/Normal Temperature 12:00	F	9H/Ultra wide Temperature 09:00
		G	3H/Wide Temperature 3:00	D	9H/Wide Temperature 09:00
		I	3H/ Ultra Wide Temperature 3:00		
9	Special Code	N	Negative voltage for LCD	T	Negative voltage and Temperature compensation for LCD
		P	Touch panel	3/5	3/5 voltage logic power supply
10	RoHS	\$			
11	Customer Code	<u>00</u> 0 ~ <u>99</u> 0 、 <u>AA</u> 0 ~ <u>ZZ</u> 0			

2. Handling Precaution

2.1 Precaution in use of LCD Module

- 2.1.1. LCD panel is made of glass. Avoid excessive mechanical shock or applying strong pressure and/or sharp tools on the surface of display area.
- 2.1.2. The polarizer placed on the display surface is easily scratched and damaged. Extreme care should be taken when handling it. To clean dust or dirt off the display surface, wipe gently with cotton, or other soft material soaked with isopropyl alcohol, ethyl alcohol, do not use water, ketone or aromatics to clear display surface, and never scrub it hard.
- 2.1.3. Keep LCD panels away from direct sunlight. The storage environment should be dust-free, clean, dry, temperature is $25^{\circ}\text{C}\pm 10^{\circ}\text{C}$ and the humidity is below 55% RH.
- 2.1.4. Do not input any signal before power is turned on.
- 2.1.5. Avoid pressing on the metal bezel, otherwise the elastomer connector could be deformed and lose contact, resulting in missing pixels and also cause rainbow on the display.
- 2.1.6. It's important to control soldering temperature and time. RoHS compliant materials might need higher temperature and time, but try to keep temperature under 350°C and time in 3-5 sec.
- 2.1.7. EL is manufactured from the organic film, and is easily affected by temperature, humidity and other environmental impact. Long time storage might cause low quality of the case. Therefore, please start production in 3 months after reception of the LCM. If in any case, long time storage over 3 months is necessary, please keep EL in vacuum package or at least in humidity $< 35\%$ RH, and temperature $25^{\circ}\text{C}\pm 10^{\circ}\text{C}$.
Note: 2.1.7. is applied to EL backlight only.

2.2 Static Electricity Precautions:

- 2.2.1. The LCD module contains a C-MOS LSI. People who operate the LCM should wear ESD protection equipment to prevent ESD hurt on products.
- 2.2.2. Do not touch any of the conductive parts such as the LSI pads; the copper leads on the PCB and the interface terminals with any parts of the human body.
- 2.2.3. Do not touch the connection terminals of the display with bare hand; it will cause disconnection or defective insulation of terminals.
- 2.2.4. The modules should be kept in anti-static bags or trays for storage.
- 2.2.5. Only properly grounded soldering irons should be used.
- 2.2.6. If an electric screwdriver is used, it should be grounded and shielded to prevent sparks.
- 2.2.7. The normal static prevention measures should be observed for work clothes and working benches.
- 2.2.8. Since dry air(almost low RH) is inductive to static, a humidity of 50-60% RH is recommended in assembly line.

2.3 Operation Precautions:

- 2.3.1. DC voltage applied on LCM causes electrochemical reactions, which will deteriorate the display over time. The applied pulse waveform should be a symmetric waveform such that no DC component remains. Be sure to use the specified operating voltage.
- 2.3.2. LCD driving voltage should be kept within specified range; excess voltage will shorten display life, while less voltage may not turn on LCM.
- 2.3.3. LCM response time will be extremely delayed in low operating temperature(such as -20°C) than in room operating temperature. Therefore, higher LCD driving voltage is required in low operating temperature; On the other hand, in high operating temperature (such as $+70^{\circ}\text{C}$) LCD shows dark background color, therefore lower LCD driving voltage is required. Be sure to use the specified LCD driving voltage in different operating temperature.

2.4 Safety:

- 2.4.1 If the LCD panel breaks, be careful not to get the liquid crystal to touch your skin.
If the liquid crystal touches your skin or clothes, please wash it off immediately by using soap and water.

2.5 WARRANTY POLICY

Bolymin .Will provide one-year warranty for the products only if under specification operating conditions.

If there are functional defects found during the period of warranty, the defective products would be replaced on a one-to-one basis.

Bolymin would not be responsible for any direct/indirect liabilities consequential to any parties.

2.6 MTBF

- 2.6.1 .By specific test condition, MTBF based on 30°C normal operation temperature is 50,000hours.

2.6.2 Test Condition:

2.6.2.1 Supply Voltage for LCM: Typical Vdd

2.6.2.2 CC (Constant Current) mode and typical current is applied for LED.

2.6.2.3 Run-Patterns: by Bolymin's test program that has defined patterns and cyclic period.

2.6.2.4 Humidity: 60%RH

2.6.3 Test Criteria:

Attenuation of average brightness: $\leq 50\%$

Increasing of current consumption for LCM/Backlight: $\leq 20\%$

Display function at room temperature: Normal

Appearance: Normal

3. General Specification

(1) Mechanical Dimension

Item	Standard Value	Unit
Number of dots	320x240	dots
Module dimension (L x W x H)	160(W)x 109.0(H)x 11.0max(T)	mm
View area	122.0(W)x 92.0(H)	mm
Active area	115.18(W)x 86.38(H)	mm
Dot size	0.34(W)x 0.34(H)	mm
Dot pitch	0.36(W)x 0.36(H)	mm

(2) Controller IC: RAIO8835

4. Absolute Maximum Rating

4.1 Electrical Absolute Maximum Ratings

(V_{SS}=0V, T_a=25°C)

Item	Symbol	Min	Max	Unit
Input Voltage	V _I	-0.3	V _{DD} +0.3	V
Supply Voltage For Logic	V _{DD} -V _{SS}	0.3	+7	V
Supply Voltage For LCD	V _{DD} -V _O	0.3	28	V

4.2 Environmental Absolute Maximum Ratings

Item	Symbol	Min	Max	Unit	Note
Operating Temperature	TOP	-20	70	°C	(1)
Storage Temperature	TST	-30	80	°C	(1) 、 (2)

Note (1)

- (a) 90 %RH Max. ($T_a \leq 40 \text{ }^\circ\text{C}$).
- (b) Wet-bulb temperature should be $39 \text{ }^\circ\text{C}$ Max. ($T_a > 40 \text{ }^\circ\text{C}$).
- (c) No condensation.

Note (2) The temperature of panel surface should be $-20 \text{ }^\circ\text{C}$ min. and $70 \text{ }^\circ\text{C}$ max.

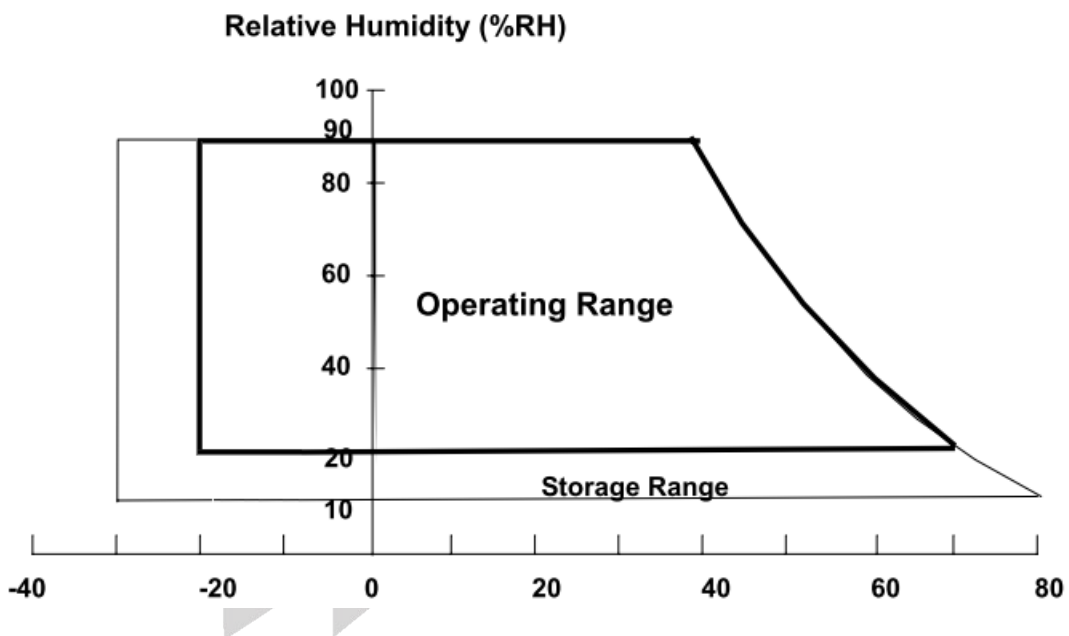

5. Electrical Characteristics

Item	Symbol	Condition	Min.	Typ.	Max.	Unit
Supply Voltage For Logic	Vdd-Vss	—	4.75	5.0	5.25	V
Supply Voltage For LCD	Vdd-Vo	Ta=25°C	23.5	23.8	24.1	V
Input High Vol	V _{IH}	—	0.5Vdd	—	Vdd	V
Input Low Vol	V _{IL}	—	0	—	0.2Vdd	V
Output High Vol	V _{OH}	—	Vdd-0.4	—	—	V
Output Low Vol.	V _{OL}	—	—	—	0.4	V
Supply Current	I _{dd}	Vdd=5V	—	100	—	mA
LCM Surface Luminance Ta=25°C	L	I _{LED} =160mA Display all ON	70	105	—	cd/m ²

※Optimum LCD driving voltage value, referring to above mentioned range, is changed due to different batch of LCD glass.

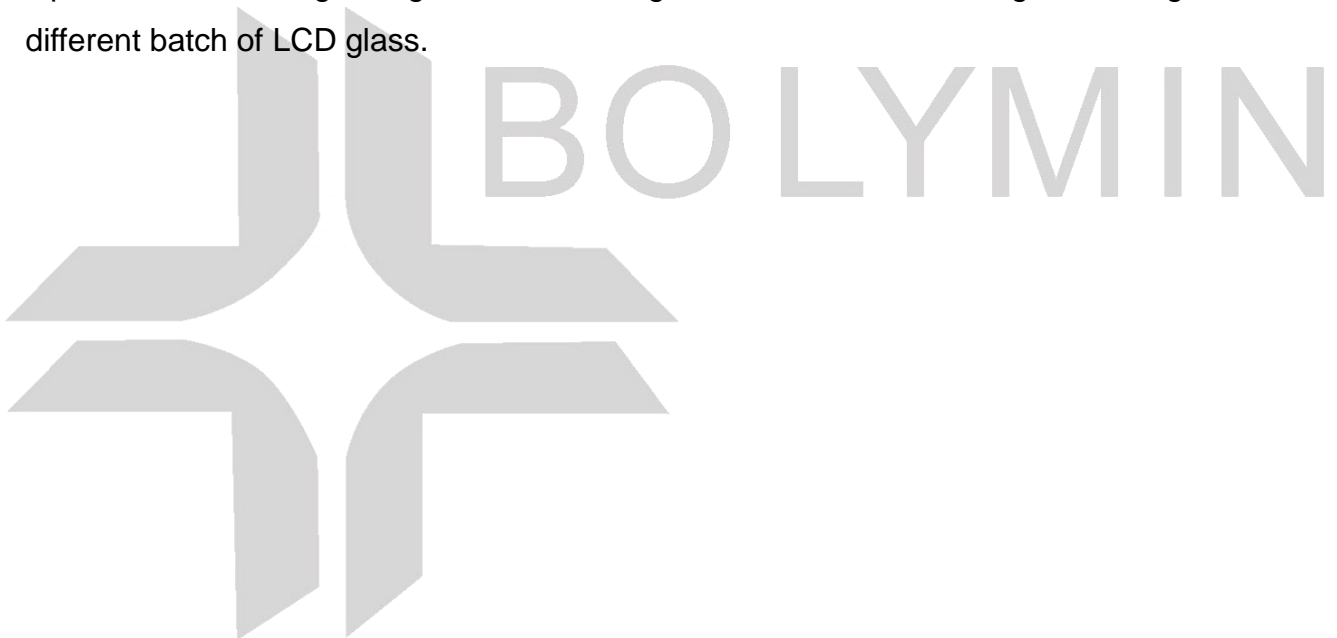

6. Optical Characteristics

a. FSTN

(Ta=25°C)

Item	Symbol	Min.	Typ.	Max.	Unit
View Angle (CR>=2)	θ_F	-	30	-	deg
	θ_B	-	35	-	deg
	φ_L	-	38	-	deg
	φ_R	-	40	-	deg
Contrast Ratio	CR	-	5	-	-
Response Time 25°C	T rise	-	200	350	ms
	T fall	-	200	400	ms

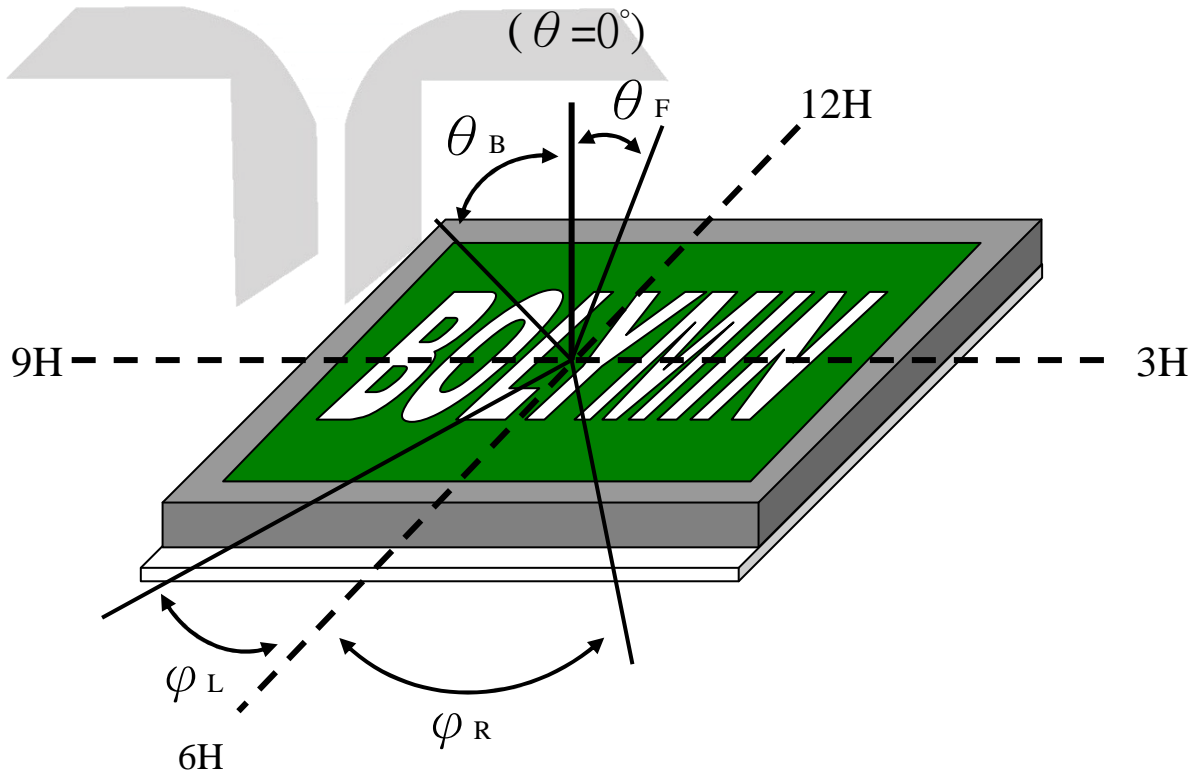

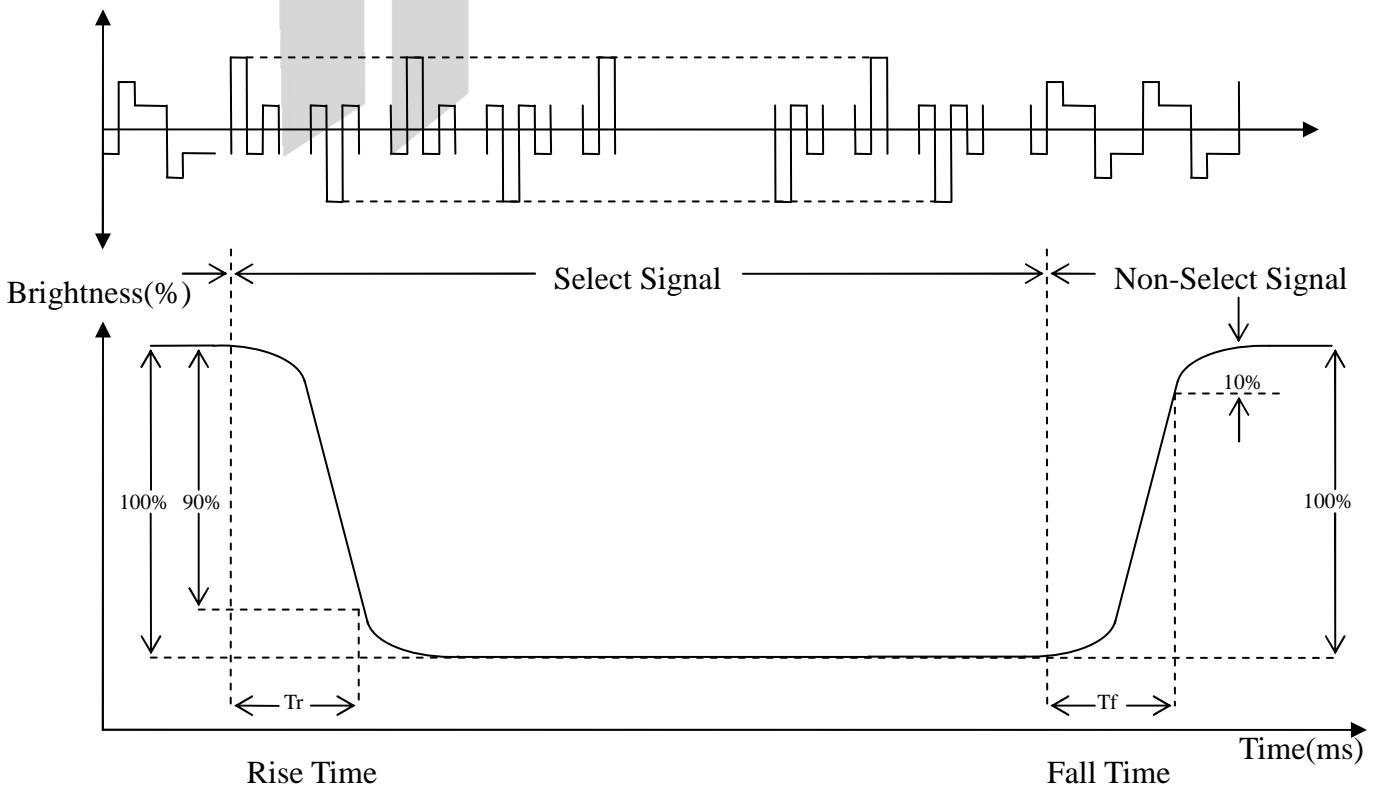
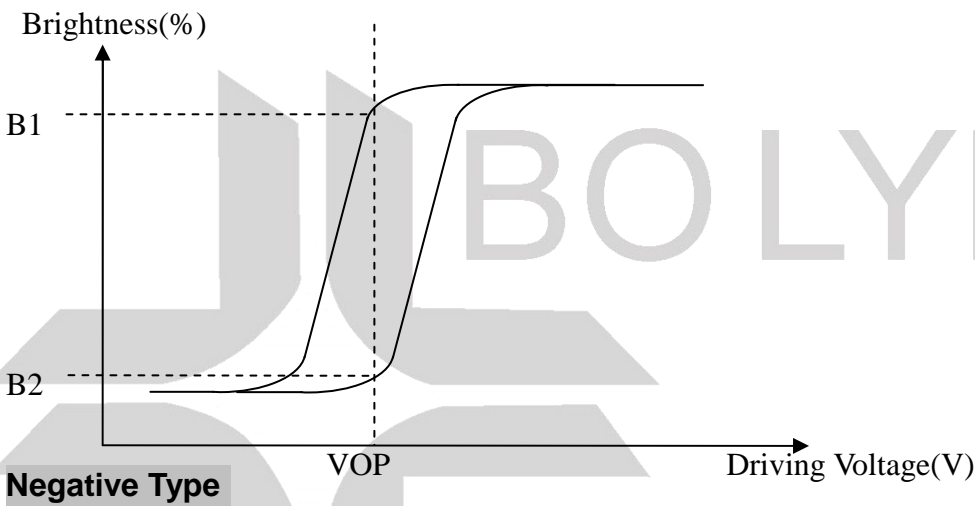
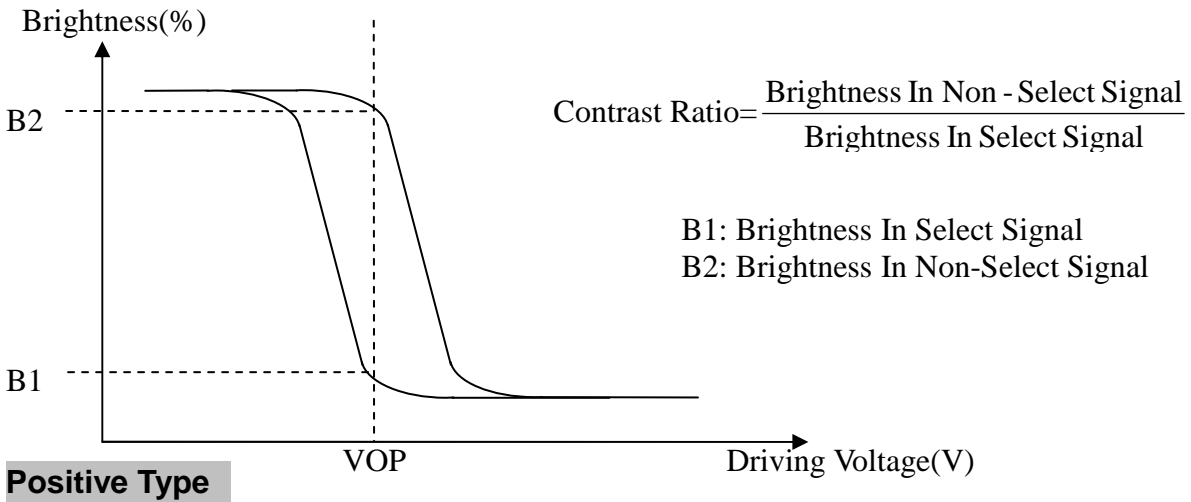

7. Interface Pin Function

Pin No.	Symbol	Level	Description
1	V _{SS}	0V	Ground
2	V _{DD}	5.0V	Power supply for Logic (option +3V)
3	V _O	(Variable)	Driving voltage for LCD
4	A0	H/L	RD=L WR=H ,A0=L :Data Read AO=H :Status read RD=H WR=L ,A0=L :Data Write AO=H :Command write
5	$\overline{\text{WR}}$	H/L	8080 family: Write signal, 6800 family: R/W signal
6	$\overline{\text{RD}}$	H/L	8080 family: Read signal, 6800 family: Enable clock
7~14	DB0~DB7	H/L	Data bus
15	$\overline{\text{CS}}$	H/L	Chip select , Active L
16	$\overline{\text{RES}}$	H/L	Controller reset signal, Active L
17	V _{EE}		Negative voltage output -21.3V (Optional)
18	SEL1		H:6800 ,L:8080
19	FGND		Frame Ground
20	NC		No connection

8. Power supply for LCD Module and LCD operating voltage adjustment

LCM operating on "DC 5V" input with built-in negative voltage

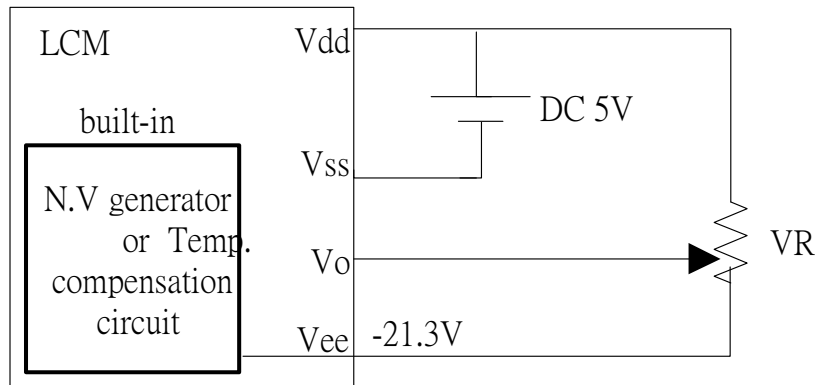

9. Backlight information

(1) LED edge / white

Parameter	Symbol	Min	Typ	Max	Unit	Test Condition
Supply Current	I _{LED}	—	160	—	mA	V=3.5V
Supply Voltage	V	3.2	3.5	3.8	V	I _{LED} =160mA
Reverse Voltage	VR	—	—	5	V	—
CIE	X	0.28	—	0.35	nm	I _{LED} =160mA
	Y	0.28	—	0.35		
Color	white					

(2) Backlight driving methods

a. LED B/L drive from A.K directly

a.1 edge/white

LCM

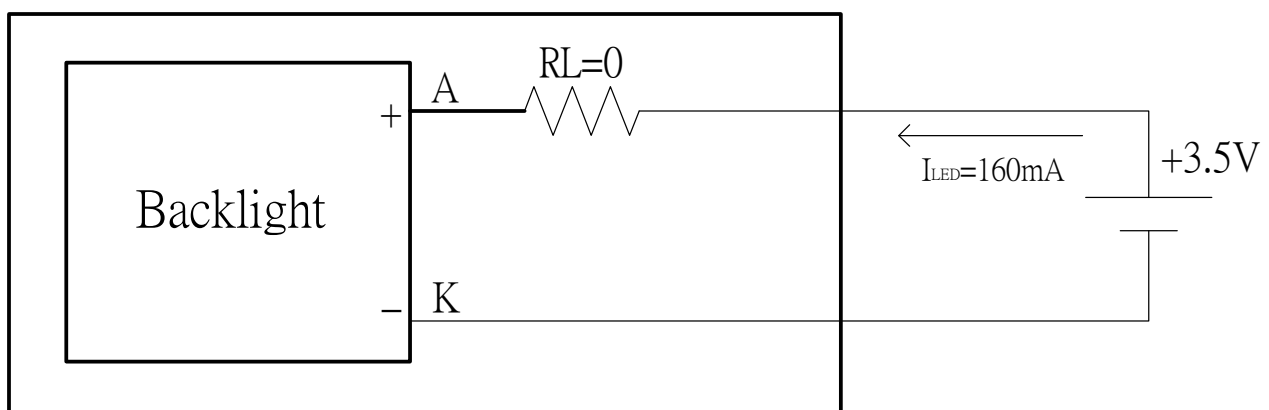

10. Quality Assurance

10.1 Inspection conditions

1. The LCD shall be inspected under 20~40W white fluorescent light.
2. Checking Direction shall be in the 40 degree from perpendicular line of specimen surface.
3. Checker shall see over 30 cm.
4. Inspect about 5 seconds for each side.
5. Defect that is located at outside of VA and doesn't affect function is ignored.

10.2 Inspection Parameters

NO.	Parameter	Criteria																								
1	Black or White spots (Particle)	<table border="1"> <thead> <tr> <th colspan="2">Zone</th> <th rowspan="2">Acceptable Number</th> <th rowspan="2">Class Of Defects</th> <th rowspan="2">Acceptable Level</th> </tr> <tr> <th>Dimension</th> <th></th> </tr> </thead> <tbody> <tr> <td colspan="2">$D \leq 0.10$</td> <td>Disregard</td> <td rowspan="4">Minor</td> <td rowspan="4">2.5</td> </tr> <tr> <td colspan="2">$0.10 < D \leq 0.2$</td> <td>4</td> </tr> <tr> <td colspan="2">$0.2 < D \leq 0.3$</td> <td>2</td> </tr> <tr> <td colspan="2">$0.3 < D$</td> <td>0</td> </tr> </tbody> </table>				Zone		Acceptable Number	Class Of Defects	Acceptable Level	Dimension		$D \leq 0.10$		Disregard	Minor	2.5	$0.10 < D \leq 0.2$		4	$0.2 < D \leq 0.3$		2	$0.3 < D$		0
		Zone		Acceptable Number	Class Of Defects	Acceptable Level																				
		Dimension																								
		$D \leq 0.10$		Disregard	Minor	2.5																				
		$0.10 < D \leq 0.2$		4																						
$0.2 < D \leq 0.3$		2																								
$0.3 < D$		0																								
$D = (\text{Long} + \text{Short}) / 2$ Total defects should not exceed 5/module Defect that is located at outside of AA and doesn't affect function is ignored.																										
2	Scratch, Substances	<table border="1"> <thead> <tr> <th colspan="2">Zone</th> <th rowspan="2">Acceptable Number</th> <th rowspan="2">Class Of Defects</th> <th rowspan="2">Acceptable Level</th> </tr> <tr> <th>X(mm)</th> <th>Y(mm)</th> </tr> </thead> <tbody> <tr> <td>—</td> <td>$0.05 \geq W$</td> <td>Disregard</td> <td rowspan="4">Minor</td> <td rowspan="4">2.5</td> </tr> <tr> <td>$4.0 \geq L$</td> <td>$0.05 \geq W$</td> <td>4</td> </tr> <tr> <td>$3.0 \geq L$</td> <td>$0.1 \geq W$</td> <td>2</td> </tr> <tr> <td>—</td> <td>$0.1 < W$</td> <td>0</td> </tr> </tbody> </table>				Zone		Acceptable Number	Class Of Defects	Acceptable Level	X(mm)	Y(mm)	—	$0.05 \geq W$	Disregard	Minor	2.5	$4.0 \geq L$	$0.05 \geq W$	4	$3.0 \geq L$	$0.1 \geq W$	2	—	$0.1 < W$	0
		Zone		Acceptable Number	Class Of Defects	Acceptable Level																				
		X(mm)	Y(mm)																							
		—	$0.05 \geq W$	Disregard	Minor	2.5																				
		$4.0 \geq L$	$0.05 \geq W$	4																						
$3.0 \geq L$	$0.1 \geq W$	2																								
—	$0.1 < W$	0																								
X: Length Y: Width Total defects should not exceed 5/module Defect that is located at outside of AA and doesn't affect function is ignored.																										

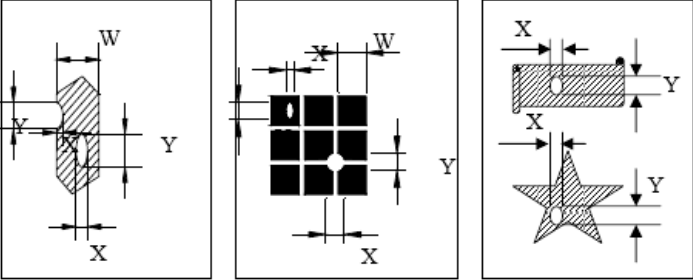
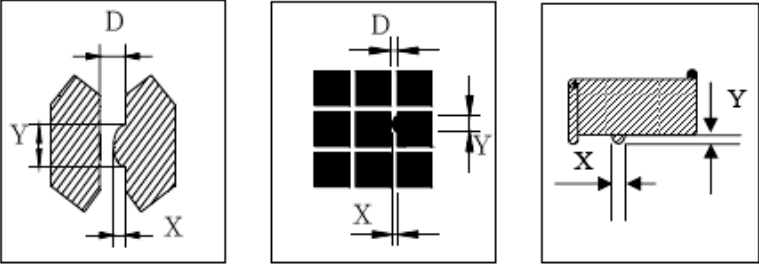
3	Air Bubbles (between glass & polarizer)	<table border="1"> <thead> <tr> <th>Zone Dimension</th> <th>Acceptable Number</th> <th>Class Of Defects</th> <th>Acceptable Level</th> </tr> </thead> <tbody> <tr> <td>$D \leq 0.2$</td> <td>Disregard</td> <td rowspan="3">Minor</td> <td rowspan="3">2.5</td> </tr> <tr> <td>$0.2 < D \leq 0.5$</td> <td>3</td> </tr> <tr> <td>$0.5 < D$</td> <td>0</td> </tr> </tbody> </table>	Zone Dimension	Acceptable Number	Class Of Defects	Acceptable Level	$D \leq 0.2$	Disregard	Minor	2.5	$0.2 < D \leq 0.5$	3	$0.5 < D$	0														
Zone Dimension	Acceptable Number	Class Of Defects	Acceptable Level																									
$D \leq 0.2$	Disregard	Minor	2.5																									
$0.2 < D \leq 0.5$	3																											
$0.5 < D$	0																											
<p>Total defects shall not excess 3/module. Defect that is located at outside of AA and doesn't affect function is ignored. Bobbles seen only under reflection light is disregarded.</p>																												
4	Displaying Pattern	<p>1. Incomplete or broken line is not allowed. 2. Pinholes</p> <table border="1"> <thead> <tr> <th>Dimension Φ(mm)</th> <th>Criteria</th> <th>Class Of Defects</th> <th>Acceptable Level</th> </tr> </thead> <tbody> <tr> <td>$\Phi < 0.1$</td> <td>Disregard</td> <td rowspan="4">Minor</td> <td rowspan="4">2.5</td> </tr> <tr> <td>$0.1 < \Phi \leq 0.2$</td> <td>2</td> </tr> <tr> <td>$0.2 < \Phi \leq 0.25$</td> <td>1</td> </tr> <tr> <td>$0.25 < \Phi$</td> <td>0</td> </tr> </tbody> </table>  <p style="text-align: center;">$\phi = (X+Y)/2$</p> <p>3. Deformation</p> <table border="1"> <thead> <tr> <th>Dimension Φ(mm)</th> <th>Criteria</th> <th>Class Of Defects</th> <th>Acceptable Level</th> </tr> </thead> <tbody> <tr> <td>$\Phi < 0.15$</td> <td>Disregard</td> <td rowspan="3">Minor</td> <td rowspan="3">2.5</td> </tr> <tr> <td>$\Phi \leq 0.25$ and $X \leq 1/2D$</td> <td>3</td> </tr> <tr> <td>$\Phi > 0.25$ and $X > 1/2D$</td> <td>0</td> </tr> </tbody> </table>  <p style="text-align: center;">D : 间距 $\phi = (X+Y)/2$</p>	Dimension Φ (mm)	Criteria	Class Of Defects	Acceptable Level	$\Phi < 0.1$	Disregard	Minor	2.5	$0.1 < \Phi \leq 0.2$	2	$0.2 < \Phi \leq 0.25$	1	$0.25 < \Phi$	0	Dimension Φ (mm)	Criteria	Class Of Defects	Acceptable Level	$\Phi < 0.15$	Disregard	Minor	2.5	$\Phi \leq 0.25$ and $X \leq 1/2D$	3	$\Phi > 0.25$ and $X > 1/2D$	0
Dimension Φ (mm)	Criteria	Class Of Defects	Acceptable Level																									
$\Phi < 0.1$	Disregard	Minor	2.5																									
$0.1 < \Phi \leq 0.2$	2																											
$0.2 < \Phi \leq 0.25$	1																											
$0.25 < \Phi$	0																											
Dimension Φ (mm)	Criteria	Class Of Defects	Acceptable Level																									
$\Phi < 0.15$	Disregard	Minor	2.5																									
$\Phi \leq 0.25$ and $X \leq 1/2D$	3																											
$\Phi > 0.25$ and $X > 1/2D$	0																											

Other Inspection standard reference Bolymin standard.

11. Reliability

■Content of Reliability Test

Environmental Test				
No	Test Item	Content of Test	Test Condition	Applicable Standard
1	High Temperature storage	Endurance test applying the high storage temperature for a long time.	80°C 96 hrs	—
2	Low Temperature storage	Endurance test applying the high storage temperature for a long time.	-30°C 96 hrs	—
3	High Temperature Operation	Endurance test applying the electric stress (Voltage & Current) and the thermal stress to the element for a long time.	70°C 96 hrs	—
4	Low Temperature Operation	Endurance test applying the electric stress under low temperature for a long time.	-20°C 96 hrs	—
5	Humidity Test	Endurance test applying the high humidity storage for a long time.	40°C, 90%RH 96hrs	—
6	Temperature cycle (Non-operation)	Endurance test applying the low and high temperature cycle. 	-30°C/80°C 10 cycles	—
7	Vibration test	Endurance test applying the vibration during transportation and using.	Total Fixed Amplitude: 1.5mm Vibration Frequency : 10~55Hz One cycle 60 seconds to 3 direction of X,Y,Z for each 15minutes	—

※Assess after placing at normal temperature and humidity for 4 hour ◦ No abnormalities in functions and appearance ◦

12. Appendix (Drawing , Block Diagram, Timing Characteristics)

12.1 Drawing

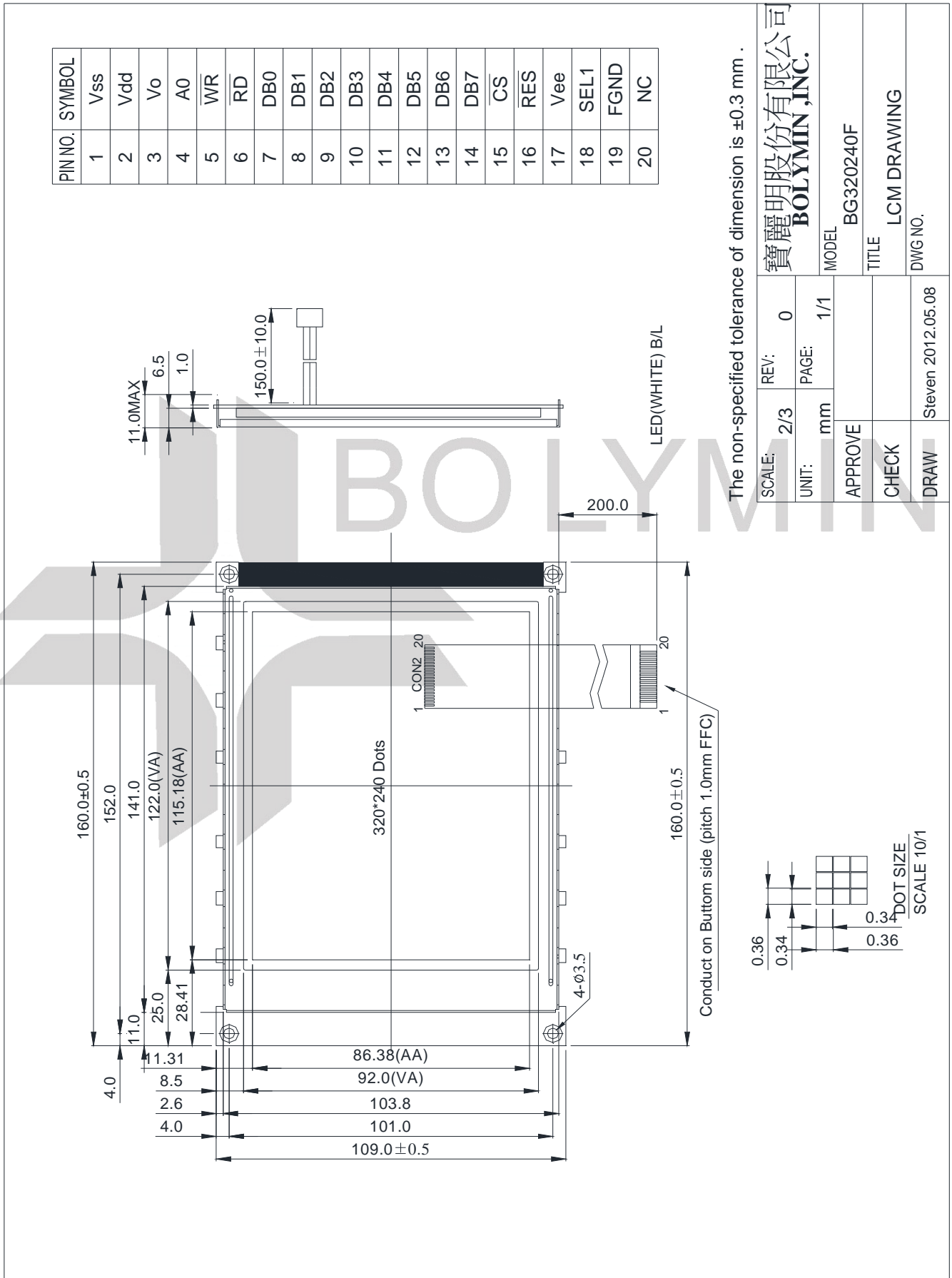

12.2 Block Diagram

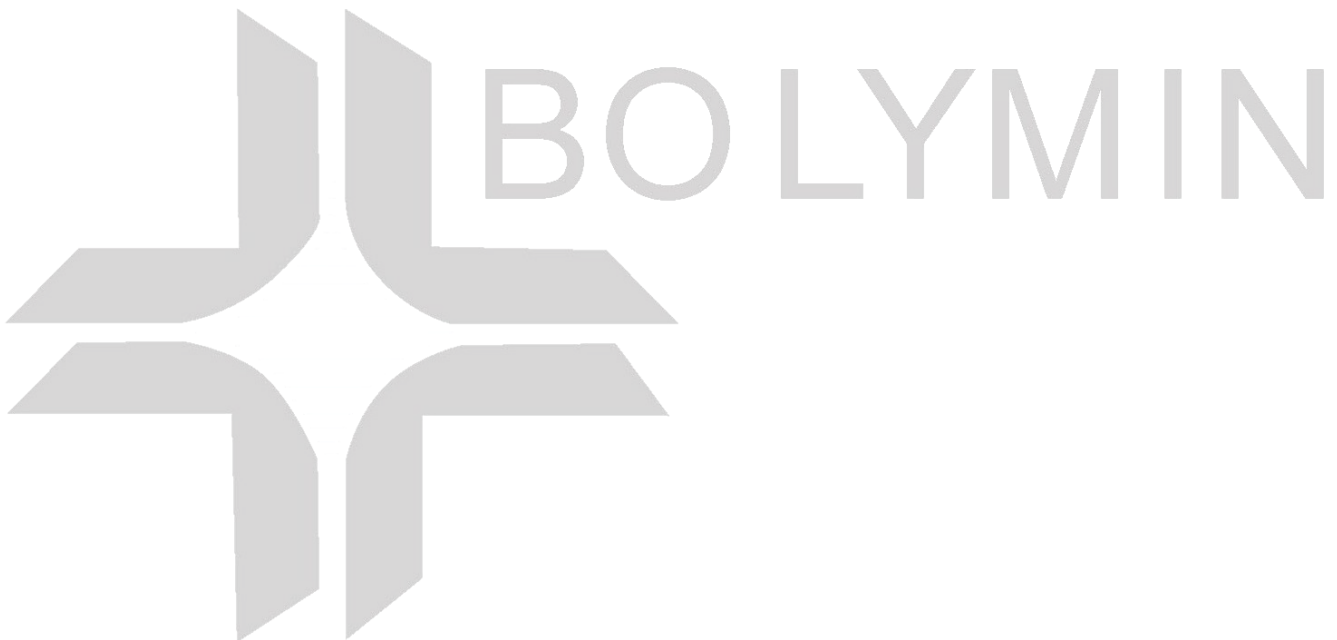
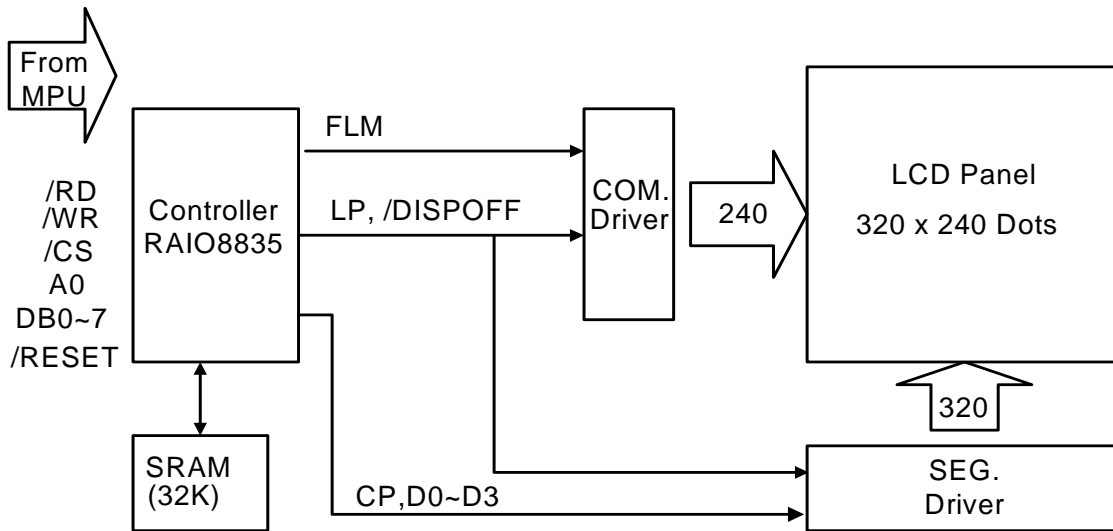

12.3 Timing characteristics

a.8080 Family Interface Timing

Parameter	Condition	Symbol	Min	Max	Unit	Remark
Address Hold Time	CL=100 pF VDD=2.7~4.5	tAH8	10		ns	A0,/CS
Address Setup Time		tAW8	0		ns	
System Cycle Time		tCYC	Note		ns	/WR,/RD
Strobe Pulse Width		tOC	150		ns	
Data Setup Time		tDS8	120		ns	DB0~DB7
Data Hold Time		tDH8	5		ns	
/RD Access Time		tACC8	-	80	ns	
Output Disable Time		tOH8	10	55	ns	

Note: For memory control and system control commands:

$$t_{CYC8} = 2t_C + t_{OC} + t_{CEA} + 75 > t_{ACV} + 245$$

For all other commands:

$$t_{CYC8} = 4t_C + t_{OC} + 30$$

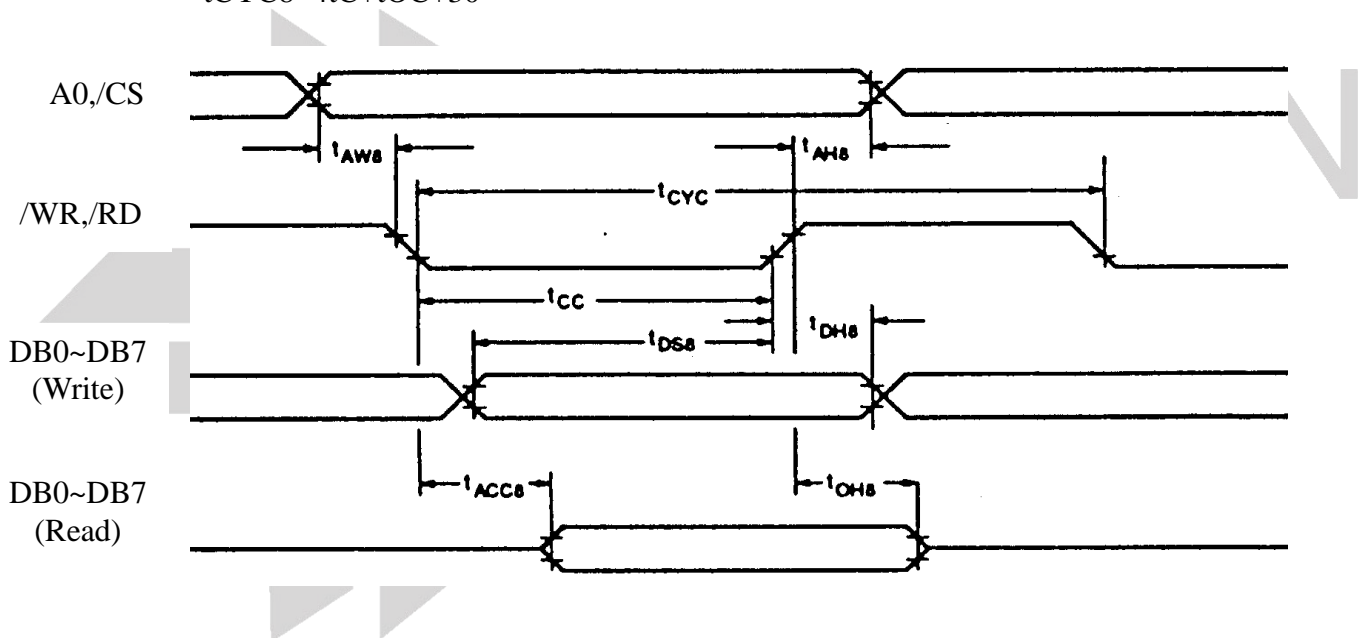

b. 6800 Family Interface Timing

Parameter	Condition	Symbol	Min	Max	Unit	Remark
System Cycle Time	CL=100 pF VDD=2.7~4.5	tCYC6	Note		ns	A0,/CS, R/W
Address Setup Time		tAW6	10		ns	
Address Hold Time		tAH6	0		ns	
Data Setup Time		tDS6	120		ns	DB0~DB7
Data Hold Time		tDH6	0		ns	
Output Disable Time		tOH6	10	75	ns	
Access Time		tACC6	-	130	ns	
Enable Pulsewidth		tEW	150	-	ns	E

Note: For memory control and system control commands:

$$t_{CYC6} = 2t_C + t_{EW} + t_{CEA} + 75 > t_{ACV} + 245$$

For all other commands:

$$t_{CYC6} = 4t_C + t_{EW} + 30$$

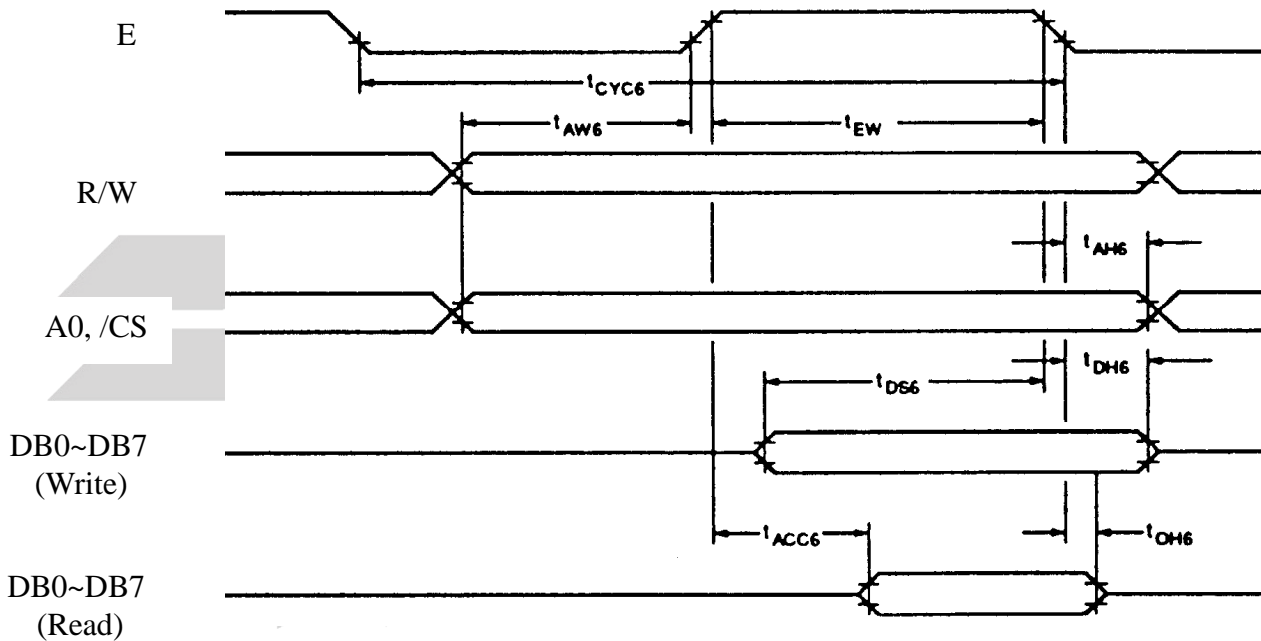

AC Electrical Characteristics

12.4 RAIO 8835A controller

Instruction Set

Class	Command	Code											Hex	Command Description	Command read parameters
		/RD	/WR	A0	D7	D6	D5	D4	D3	D2	D1	D0			Number of bytes
System Control	SYSTEM SET	1	0	1	0	1	0	0	0	0	0	0	40	Initialized Device and display	8
	SLEEP IN	1	0	1	0	1	0	1	0	0	1	1	53	Enter Standby mode	0
Display Control	DISP ON/OFF	1	0	1	0	1	0	1	1	0	0	D	58, 59	Enable and disable display and display flashing	1
	SCROLL	1	0	1	0	1	0	0	0	1	0	0	44	set Display start address and display regions	10
	CSRFORM	1	0	1	0	1	0	1	1	1	0	1	5D	Set cursor byte	2
	CGRAM ADDR.	1	0	1	0	1	0	1	1	1	0	0	5C	Set start address of character generator RAM	2
	CSRDIR	1	0	1	0	1	0	0	1	1	CD	CD	4C to 4F	Set direction of cursor movement	0
	HDOT SCR	1	0	1	0	1	0	1	1		1	0	5A	set horizontal scroll position	1
	OVLAY	1	0	1	0	1	0	1	1	0	1	1	5B	set display overlay format	1
Drawing Control	CSRW	1	0	1	0	1	0	0	0	1	1	0	46	set cursor address	2
	CSRR	1	0	1	0	1	0	0	0	1	1	1	47	read cursor address	2
Memory Control	MWRITE	1	0	1	0	1	0	0	0	0	1	0	42	write to display memory	-
	MREAD	1	0	1	0	1	0	0	0	0	1	1	43	read from display memory	-

Note:

- In general, the internal registers of the RAIO 8835A are modified as each command parameter is input. However, the microprocessor does not have to set all the parameters of a command and may send a new command before all parameters have been input. The internal registers for the parameters that have been input will have been changed but the remaining parameter registers are unchanged. 2 bytes parameters(where two bytes are treated as 1 data item) are handled as following:
 - CSRW, CSRR: Each byte is processed individually. The microprocessor may read or write just the low byte of the cursor address.
 - SYSTEM SET, SCROLL, CGRAM ADR. : Both parameter bytes are processed together. If the command is changed after half of the parameter has been input, the single byte is ignored.
- APL and APH are 2-byte parameters, but are treated as two 1-byte parameters.
- Please refer to RAIO 8835A LCD Controller Data Book for detail.